

A New Model Applied to the Planning of Distribution Systems for Competitive Electricity Markets

V. V. Thang

Department of electric power systems
Thainguyen University of Technology (TNUT)
Thainguyen, Vietnam
thangvvhtd@tnut.edu.vn

D. Q. Thong and B. Q. Khanh

Department of electric power systems
Hanoi University of Science and Technology (HUST)
Hanoi, Vietnam
bq_khanh-htd@mail.hut.edu.vn

Abstract - Recently, the restructuring of electricity market and the development of technology have been enhancing the application of distributed generators (DGs) and renewable energy resources. Hence, the planning of distribution systems (PDS) for competitive electricity markets (CEMs) has encountered impacts which need to be investigated. This paper proposes a novel approach for optimizing distribution system planning in CEMs with the presence of DGs. The proposed model can determine equipment sizing and timeframe required for upgrading power network in order for utilities to purchase electric energy from electricity markets. Besides, the problems of DG system development (Optimal DG displacement, sizing, technology selection and installation period) in distribution planning to meet the demand growth will be solved. The model uses the objective function that minimizes the total cost of network (feeders and transformers) upgrading, new DGs installation, distribution systems operating, and electric energy purchasing from CEMs. The proposed model is tested using an 33 bus 22kV radial feeder. The calculation is programmed in GAMS environment.

Keyword: *Distributed Generator (DG), Planning of Distribution System (DS), Competitive Electricity Markets (CEM)*

I. INTRODUCTION

Recently, the issue of planning of DS has gained remarkable achievements. Because of the construction of competitive electricity market (CEM), technological development and environmental pollutions, the development of DG and renewable energy resources, in particular, is fostered [1].

DGs connected directly to DSs or supplied straight to customers [2], normally use new electric generating technologies such as gas turbines, Combined Heat and Power (CHP), Fuel Cells, solar energy, geothermal and wind energies. The power of DGs can reach to 300MW depending on particular technologies, but the power in use of DGs is normally less than 5MW. The DG is installed close to loads so that it gets some main advantages including the elimination of transmission and distribution cost, enhancement of flexibility and reliability of distribution systems, reduction of power loss, and improvement of differential voltage at nodes as well as reduction of environmental pollution because of using renewable energy resources [2]. However, DGs require high

investment [3], increase the complexity in measurement and relay protection and operation of DSs. By using mathematical programming or heuristic programming, many authors have already proposed planning models of DSs that have objective function involving one or more objectives. A single-objective planning model can aim at minimizing total active power loss [4, 5] of DS including DG. Material [6] introduced two objective models consisting of minimum loss of total active power and allowed voltage drop limitation. Another planning model having three objectives comprises the first that is the construction and operation costs of DG as well as energy expense from market, the second that is the cost of power loss and the third, which is the cost of environmental pollution. These three objectives are used to estimate the location, capacity of DG in CEM [7]. Similarly, a different planning model including total power cost, loss and minimum voltage drop is given in [8].

A significant change in DSs planning is the reconstruction of electricity markets with source, price constraints in recent years. Therefore, using DG is a new planning approach. Most of researches mainly focus on one-objective models which combine of construction and operation costs in order to determine capacity, location and a new building investment process or to upgrade current equipments by using popular mathematical programming. A new model is proposed to plan DSs in long-term in [9] when considering DG source planning schemes. In this research, the objectives are the minimum summary of investment and operation costs of DG, the investing cost of feeder and substation transformers during planning period, and goodness indices (incremental loss indices and incremental feeder loading indices) are also represented. The DG technology is not mentioned due to the assumption that the costing functions and effects of DG in DSs planning are the same, but they are impossible in reality. Another model, which owns objectives consisting of the total investing and operating costs of DG, feeders and substation transformers upgrading costs, energy expenses and minimum interruptible load costs is shown in [10]. In this model, effects of DG technology are not mentioned in selecting variables.

Environmental pollution is one of the burning issues worldwide nowadays. Traditional energy resources generate immense impacts to environment, whereas high-tech DG and

clean, renewable energy resources create a very small pollution. Hence, in the planning of DSs comprising polluted air index, [11] shows a two-stage planning model. The minimum of total costs of upgrading feeders, substation transformers and DGs construction, energy expenses purchased from market and environmental pollution costs is applied as the objective in this research. The heuristic programming method illustrated in [12] with the objective is the minimization of total costs of construction, upgrading and operation fees, feeder, substation transformers and DG, energy expenses of DSs. This method does not use binary variables so that the computation burden is reduced significantly.

Effects of CEM, energy policies, environmental pollution problem and development of technology emerge new constraints that lead to using DG in DSs planning as a new solution. This research proposes a new approach to DS planning that considers DGs as an optimal selection. The objective function is minimum amount of total costs including investing and upgrading costs of feeder and substation transformers, building cost of new DGs, and operating fees, as well as fuel of DG and energy expenses purchased from market via connected substation transformers. All these costs are converted to the first year of planning period. In order to meet the technical criterions, model's constraints consist of nodal power balance between supplies and load demands, DG power limitation, efficiency of existing equipments, required nodal voltage drop. The calculation tool to solve this proposed planning problem is the GAMS program language.

The next parts of this paper are organized as follows. Section II introduces a model of the proposed DS planning problem with objective function and constraints. Section III represents calculation results from the 33nodes, 22kV distribution system. Conclusion is reported in Section IV.

II. PROPOSED A NOVEL DISTRIBUTION SYSTEM PLANNING MODEL

In CEM, distribution systems are managed by distribution companies (Discos). In order to meet load demands in future, these companies can buy electrical energy from CEM via power system connected substation transformers or to coordinate to invest DGs. As DGs are chosen in DSs planning, economic and technical indices of planning project are changed which affects considerably to time, upgrading capacity and improvements of feeders and substation transformers.

A. Objective Function

A medium-term planning of DS is proposed in this article. The objective is to maximize profits of Discos or to minimize total investing and operating costs. Therefore, the objective function is minimum quantity of total costs of constructing and upgrading investments for existing feeder and substation transformers, new construction of DGs, operating and fuel costs of DGs and energy expenses are bought from electricity market during planning horizon. The proposed model is an one-stage nonlinear programming model with decided variables are continuous. For the purpose of calculation reduction, these results are rounded to suitable values which appropriate to existing equipments. This model also allows

selecting technology of DG through economic and technical indices. All costs during are calculated at the same time that is the first time of planning period by using discount rate r . (1) gives the objective function J of the proposed planning problem in new conditions:

$$J = \sum_t \frac{1}{(1+r)^t} \left(\sum_{i=1}^N \sum_{j=1}^N (C^{FF} + C^{FC} \cdot S_{i,j,t}^F) L_{i,j} \right) \textcircled{1} \\ + \sum_{i=1}^{NS} (C^{SF} + C^{SC} \cdot S_{i,t}^S) \textcircled{2} + \sum_{i=1}^{NDG} \sum_{k=1}^{KDG} C_k^{DG} \cdot S_{i,k,t}^{DG} \textcircled{3} \\ + T_{max} \cdot \sum_{i=1}^{NS} (r_P^S \cdot P_{i,t}^S + r_Q^S \cdot Q_{i,t}^S) \textcircled{4} \\ + T_{max} \cdot \sum_{i=1}^{NDG} \sum_{k=1}^{KDG} (r_k^{PDG} \cdot P_{i,k,t}^{DG} + r_k^{QDG} \cdot Q_{i,k,t}^{DG}) \textcircled{5} \rightarrow Min$$

Where: $\frac{1}{(1+r)^t}$ calculated total cost at base year;

Components in $\textcircled{1}$ are upgrading cost of feeders for year t with fixed capital cost (C^{FF}) and variable capital cost (C^{FC}). substation transformers upgrading costs in year t with fixed capital cost (C^{SF}) and variable capital cost (C^{SC}) in $\textcircled{2}$. $\textcircled{3}$ are new investment costs of DGs at node i , year t with DG technologies k . Electrical energy purchased cost from CEM in $\textcircled{4}$ and $\textcircled{5}$ are O&M and fuel costs of DG depending per technology.

TABLE I. SETS, INDICES, VARIABLES AND PARAMETERS

No	Symbol	Definition
I. Sets and Indices		
1	N	Set of buses in distribution system
2	i, j	Bus ($i, j \in N$)
3	NL	Set of load buses in distribution system
4	NS	Set of substation buses in distribution system
5	NDG	Set of DG buses in distribution system
6	T	Overall planning period, year
7	t	Planning period ($t \in T$)
8	KDG	Total number of DG's technology
9	k	Technology of DG ($k \in KDG$)
II. Variables		
10	$P_{i,t}^S$	Active power purchased from CEM at node i , for year t (MW)
11	$Q_{i,t}^S$	Reactive power purchased from CEM at node i , for year t (MW)
12	$S_{i,j,t}^F$	Upgrading capacity of Feeder ij for year t (MVA)
13	$S_{i,t}^S$	Upgrading capacity for Substation i , at year t (MVA)
14	$S_{i,k,t}^{DG}$	New investment capacity of DG node i for technology k , at year t (MVA)
15	$P_{i,k,t}^{DG}$	Active power of DG node i , for technology k , at year t (MW)
16	$Q_{i,k,t}^{DG}$	Reactive power of DG node i , for technology k , at year t (MVA _r)
17	$U_{i,t}$	Voltage for node i , at year t (pu)
18	$\delta_{i,t}$	Voltage angle at bus i , for year t (radian)
III. Parameters		
19	r	discount rate (%)
20	C^{FF}	Fixed capital cost of Feeder (\$/km)
21	C^{FC}	Variable capital cost of Feeder (\$/MVA.km)
22	$L_{i,j}$	Length of Feeder ij (km)
23	Y_{ij}	Magnitude of admittance matrix element ($1/\Omega$)

TABLE I. Continued

No	Symbol	Definition
24	θ_{ij}	Angles of admittance matrix elements (radian)
25	C^S	Fixed capital cost of Substation (\$)
26	C^{SC}	Variable capital cost of Substation (\$/MVA)
27	C_k^{DG}	New investment cost for DG technology k (\$/MW)
28	ρ_P^S	Active power purchased cost from CEM (\$/MWh)
29	ρ_Q^S	Reactive power purchased cost from CEM (\$/MVarh)
30	ρ_k^{PDG}	O&M cost and Fuel cost of DG for active energy (\$/MWh)
31	ρ_k^{QDG}	O&M cost and Fuel cost of DG for reactive energy (\$/MVarh)
32	$PD_{i,t}$	Active power demand at bus i, for year t (MW)
33	$QD_{i,t}$	Reactive power demand at bus i, for year t (MVar)
34	$P_{max,k}^{DG}$	Maximum DG capacity limit for active power with technology k (MW)
35	$Q_{max,k}^{DG}$	Maximum DG capacity limit for reactive power with technology k (MVar)
36	U_{max}	Maximum voltage limit at bus (pu)
37	U_{min}	Minimum voltage limit at bus (pu)
38	ΔP	Active power ramp-up limit for DG in planning year (MW)
39	ΔQ	Reactive power ramp-up limit for DG in planning year (MVar)
40	ΔS	Capacity ramp-up limit for Substation transformer in planning year (MVA)
41	f_{SL}	Load factor of Substation transformer base year

B. The DS planning constraints

Optimal planning of DS with objective function satisfying economic and technical requirements will be guaranteed when all constraints including nodal power balance between supplies and load demands, maximum DG power limitation, nodal voltage drop, required and limited capacity of power system connected substation transformers are matched.

1) Constraint nodal power balance

In estimation of distribution grids, nodal power should be balanced to make sure the balance of capacity of the whole system. Nodal power balance in a grid for nodal loads [9] is given as follows (2).

$$\begin{aligned}
 PD_i + \sum_{j=1}^N |Y_{ij}| |U_i| |U_j| \cdot \cos(q_{ij} - d_j - d_i) &= 0 \\
 QD_i - \sum_{j=1}^N |Y_{ij}| |U_i| |U_j| \cdot \sin(q_{ij} - d_j - d_i) &= 0 \quad (2) \\
 \forall i, j \in N
 \end{aligned}$$

Constraint of nodal power balance in (2) is only used for nodal loads, when DSs planning considers the use of DG with different time and technologies, the previous formula is rewritten as (3 and 4).

$$\begin{aligned}
 \sum_{k=1}^{KDG} P_{i,k,t}^{DG} + P_{i,t}^S - PD_{i,t} &= \sum_{j=1}^N |Y_{ij}| |U_{i,t}| |U_{j,t}| \cdot \cos(q_{ij} - d_{j,t} - d_{i,t}) \\
 \forall i, j \in N, t \in T, k \in KDG \quad (3) \\
 P_{i,k,t}^{DG} \geq 0, \forall i \in N, t \in T, k \in KDG
 \end{aligned}$$

$$\begin{aligned}
 \sum_{k=1}^{KDG} Q_{i,k,t}^{DG} + Q_{i,t}^S - QD_{i,t} &= - \sum_{j=1}^N |Y_{ij}| |U_{i,t}| |U_{j,t}| \cdot \sin(q_{ij} - d_{j,t} - d_{i,t}) \\
 \forall i, j \in N, t \in T, k \in KDG \quad (4)
 \end{aligned}$$

$$Q_{i,k,t}^{DG} \geq 0, \forall i \in N, t \in T, k \in KDG$$

2) Constraint of limited nodal voltage

It is much important to voltage quality in DS using less regulated voltage devices mainly provides to electric devices directly. In such DS, voltage quality cannot be good due to large voltage loss. Therefore, in order to meet technical requirements, allowed voltage drop must be in range with full loads. Voltages at substation nodes are assumed constants, constraint of limited nodal voltage then is give as (5).

$$\begin{aligned}
 U_{min} \leq |U_{i,t}| \leq U_{max} \quad i \in NL \\
 |U_{i,t}| = constan \quad i \in NS \quad (5)
 \end{aligned}$$

3) Constraint of DG capacity limits and Dynamic capacity updates

This constraint allows computed DG capacity at nodes in limit of DG technology, and it ensures annually upgrading power corresponding to equipment parameters (6 and 7).

$$P_{i,k,t}^{DG} \leq P_{max,k}^{DG}, Q_{i,k,t}^{DG} \leq Q_{max,k}^{DG} \quad i \in NDG, k \in KDG \quad (6)$$

$$\begin{aligned}
 P_{i,k,t}^{DG} = P_{i,k,t-1}^{DG} + DP, Q_{i,k,t}^{DG} = Q_{i,k,t-1}^{DG} + DQ \\
 t \geq 1, i \in NDG, k \in KDG \quad (7)
 \end{aligned}$$

4) Constraint of ST capacity limits and Dynamic capacity updates

With the assumption that substation transformers are ensuring electric supply for load demands of current DS to make use of existing substation transformers capacities and to satisfy annually upgrading power corresponding to equipment parameters. This constraint is given as follows:

$$S_{i,t}^S \geq f_{SL} \cdot S_{i,1}^S \quad t \geq 1, i \in NS \quad (8)$$

$$S_{i,t}^S \geq S_{i,t-1}^S + DS \quad t \geq 1, i \in NS \quad (9)$$

The planning model from formula (1) to (9) is a nonlinear programming model. The proposed investigation uses NLP or MINLP solver in GAMS program language [13] to find out an optimal solution.

III. RESULTS AND DISCUSSIONS

Distribution systems normally use popular radial diagram that has advantages such as low-cost, easy operation, lower power and electricity energy losses. However, the reliability is lower since all loads would be interrupted if failure were occurred at source side. Therefore, it should be used for loads which require not so high electric quality and reliability. When DG is connected to the DS, these disadvantages can be

overcome. Hence, this structure is popular despite of increased complexity of relay protection. The IEEE 33bus radial structure is investigated in this research. Parameters are changed to match the problem.

A. Diagram and Parameters of 33bus radial distribution system

Figure 1 illustrates the IEEE 33bus radial structure that has 22kV with substation transformer node connected to 110kV grid and 32 load nodes. The total active power and reactive power at the base year are 10,675.0kW and 9,040.0kVAR, respectively. Load data is in APPENDIX A. Total length of feeders is 41.7km with detailed parameters in APPENDIX A.

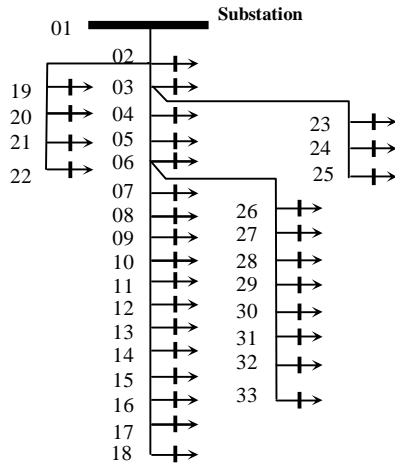

Figure 1. Diagram of 33bus IEEE radial distribution system

B. Analysis and Discussions

To estimate and test the feasibility of the proposed model, the above radial diagram is used to investigate with parameters and assumptions as follows.

1) Assumptions in analysis

This research utilizes some economic and technical assumptions for the ease of computation:

- Planning period is 5 years. Annual developing rate of load demand is constant at 5% during planning time. Hence, the total increased load demand is 25%.
- The investing and operating costs are converted to the first year of planning with discount rate is 10%, annually.
- Current substation is capable of supplying to load demand at base year. Hence, to make use of existing equipments, minimum load fact of substation in this model is 0.9.
- The constructing cost of 110kV substation includes fixed costs (land clearance, design, tax...) and variable costs (equipment expenses) are 0.2M\$ and 0.05M\$/MVA, respectively [3]. Similarly, the upgrading costs of 22kV feeders consist of 0.15M\$/km for fixed costs and 0.001M\$/MVA.km for variable costs. These parameters are shown in Table II.

TABLE II. TOTAL COST OF FEEDERS AND TRANSFORMERS UPGRADING [3]

No	Resource	Fixed capital cost	Variable capital cost
1	Substation	200.000 \$	50.000 \$/MVA
2	Feeder	150.000 \$/km	1000 \$/MVA

- Energy expenses from CEM via substations are 100\$/MWh and 60\$/MVARh corresponding to active and reactive energy [3].
- DG technology is not mentioned in detail. The effects of DG technology, however, are represented by investment, operation and fuel costs. Two DG technologies namely, solar photovoltaic (PV) and small gas turbine sources, are used in this research with the corresponding capital costs to be 5.0M\$/MW and 0.5M\$/MW. Average O&M and fuel costs depend on used technology and they are shown in Table III.

TABLE III. CAPITAL, O&M AND FUEL COST OF DGs [3]

No	DG technology	Capital cost (M\$/MW)	O&M cost (\$/MWh)	Fuel cost (\$/MWh)
1	Gas turbine	0.5	10	80
2	Solar PV	5	1	0

- Constraint of limited load nodal voltage is changed from 0.9pu to 1.1pu, and it should be 1.05pu at substation node.
- Since advanced DG technology is mature, integrated-DG compact modules occupy small spaces and install in short time. Moreover, installing areas at load locations are no limit. Only one DG per technology is chosen at each load location. However, it can be selected more than one DG technology simultaneously at each load location. Each planning year, additional power of DG should be 0.1MW.
- Upgrading areas of substation transformers and feeders are not limited so that only existing equipments can be upgraded. Each planning year, additional capacity of the 110kV transformer should be 16MVA corresponding to devices in market. Upgrading feeder capacity is suitable to cross-section of selected feeders.
- Decided variables (feeder and ST upgrades, DG investment) in the proposed model are continuous in order to reduce the complexity of the model (not need to use binary variable). Hence, they should be rounded to match real equipments

2) Analysis results of cases

The feasibility of the proposed model and efficiency of DG are investigated by two cases in the 33bus radial diagram. Case A, in which DG is not considered, decides an upgrading time for feeders and substations. Case B is similar to Case A but DG is mentioned in the researching model.

a) Case A

This case aims to estimate the working capacity of current feeders and substations as load demands in future. Furthermore, upgrading time and capacity of them will be decided to ensure requirements within planning period.

Decision of an optimal planning model in term of 5-year planning is illustrated in Table IV and V.

TABLE IV. SUSTATION TRANSFORMER UPGRADING DECIDED - CASE A

No	Substation Transformer	Substation Transformer upgrading capacity in each year (MVA)					Capacity in base year (MVA)	Total capacity of Substation Transformer (MVA)
		1	2	3	4	5		
1	1	16	-	-	-	-	16	32

TABLE V. FEEDERS UPGRADING DECIDED - CASE A

No	Feeder	Capacity in base year (MVA)	Feeder section upgrading in each year (mm ²)					Feeder capacity upgrading in each year (MVA)					
			1	2	3	4	5	1	2	3	4	5	
1	1-2	16.96	-	240	-	-	-	23.24	-	-	-	-	-
2	2-3	16.96	-	-	-	185	-	-	-	-	19.43	-	-
3	3-4	12.57	150	-	-	-	-	16.9	-	-	-	-	-
4	4-5	12.57	-	150	-	-	-	16.9	-	-	-	-	-
5	5-6	12.57	-	-	120	-	-	-	-	14.48	-	-	-
6	8-9	4.95	-	-	35	-	-	-	-	6.67	-	-	-
7	9-10	4.95	-	-	-	-	35	-	-	-	-	-	6.67

The above results show that substation transformer need to upgrade a 16MVA capacity at the first year in order to meet the 5% increased demand. Similarly, feeders are also need to upgrade depending planning time. Feeders which are close to the substation transformer (from this substation to 6th node and from 8th to 10th node) must be upgraded at the first years of planning period (23.24MVA corresponding to 240mm² is the greatest upgrading capacity at the feeder from 1 to 2 node and 6.67MVA corresponding to 35mm² is the smallest upgrading capacity at 9-10 feeder). Upgrading time is lasted within the planning period. In the first year, the 3-4 feeder must be added 16.9MVA and the capacity of 9-10 feeder then must be added in the final year by 6.67MVA.

TABLE VI. TOTAL INVESTMENT, O&M AND ENERGY PURCHASED FROM CEM COST OF CASE A

No	Cost	Investment, O&M and Energy purchased from CEM in each year (M\$)					Total cost (M\$)
		1	2	3	4	5	
1	Substation Transformer upgrading	1.00	-	-	-	-	1.00
2	Feeder upgrading	0.25	0.51	0.48	0.5	0.24	1.98
3	O&M and Electrical energy	8.57	9.06	9.55	10.06	10.58	47.82
Total							50.80

In this case, costs for feeders and substation transformer upgrading which are converted to the base year, are 2.98M\$ and energy costs correspond to 47.82M\$ shown in Table VI. As a result, the total costs of case A are 50.80M\$.

b) Case B

DG technology is utilized in this case. Solar PV energy (PV type) and Gas turbine with opposed economic indices are used in this investigation and they are shown in Table III. Maximum

power of DG can be selected by 2.0MW, PV is only capable of providing active power while Gas turbine can supply both active and reactive powers with 0.8 power factor. Parameters of DGs in Table VII are used in computation of GAMS environment.

TABLE VII. DATA OF DGs [3]

No	DG technology	P _{min} (MW)	P _{max} (MW)	Q _{min} (MVA _r)	Q _{max} (MVA _r)	Cca (M\$/MW)	Cpo (\$/MWh)	Cqo (\$/MVA _r h)
1	Solar PV	0	2	0	0	5	1	0
2	Gas turbine	0	2	0	1.5	0.5	90	10

* Where: Cca - Capital cost of DG; Cpo, Cqo - O&M and Fuel cost of DG

Table VIII presents decisions optimal investment of proposed planning model for DG. During planning time, it is advisable to invest new DGs with 5.6MW in total equal to 52.46% of base year's load demands. Investment of DG focuses mainly on early years of planning period and chooses both assumption technologies. PV is chosen for 18th and 33rd nodes at the third year with 0.4MW and 0.2MW, respectively. Gas turbine is decided immediately at the first year for 18th, 22nd and 33rd nodes with 1.2MW, 2.0MW and 0.6MW, respectively. In the third year, 1.2MW is added at 18th node.

TABLE VIII. DG INVESTMENT DECIDED

DG technology	Bus	DG capacity invested in each year (MW)					Capacity in base year (MVA)	Total capacity of DG (MVA)
		1	2	3	4	5		
Solar PV	18	-	-	0.4	-	-	0	0.4
	33	-	-	0.2	-	-	0	0.2
Gas turbine	18	1.2	-	1.2	-	-	0	2.4
	22	2.0	-	-	-	-	0	2.0
	33	0.6	-	-	-	-	0	0.6
Total		3.8	0.0	1.8	0.0	0.0	0	5.6

The selected location of DG is far from the substation transformer, namely, 18th and 33rd nodes so that high economic and technical efficiencies are gained. A decreased transforming capacity from the source to remote loads leads to a reduction of power loss, electricity energy loss and operating cost. It also improves voltage profile and reliability.

In general, DGs owning high investments offer a cheap energy price, PV source in particular. Hence, early investment will achieve high effectiveness since cheap energy price is utilized during final years of planning period. Therefore, all DGs are invested early and they are mainly used at the first year with 3.8MW.

Electricity energy purchased from CEM via substation transformer and capacities of feeders have both been decreased so that the upgrade of feeders and substation transformer can be delayed as shown in Table IX. Consequently, compared to case A, investing costs of feeders and substation transformer have been reduced by 1.98M\$ in this case.

TABLE IX. FEEDER UPGRADING DECIDED - CASE B

No	Loại thiết bị	Capacity upgrading in each year (MVA)				
		1	2	3	4	5
1	Feeder, i-j	-	-	-	-	-
2	Substation Transformer, l	-	-	-	-	-

Compared to case A, the construction cost is raised by 2.52M\$ since DGs investing cost is 5.5M\$. However, O&M and fuel expenses of DGs are low so the total costs of case B are just only 46.24M\$ as detailed in Table X.

TABLE X. TOTAL INVESTMENT, O&M AND ENERGY PURCHASED FROM CEM COST OF CASE B

TT	Cost	Investment, O&M and Energy purchased from CEM in each year (M\$)					Total cost (M\$)
		1	2	3	4	5	
1	Substation Transformer upgrading	-	-	-	-	-	0
2	Feeder upgrading	-	-	-	-	-	0
3	Investment DG	1.9	0.0	3.6	0.0	0.0	5.5
4	O&M and Electrical energy	7.66	8.10	8.12	8.34	8.52	40.74
Total							46.24

3) Comparisons of economic and technical indices

The optimal decision of the proposed model, when the two cases are tested, shows the optimal upgrading process (time and capacity) of selected substation transformer and feeders. Moreover, optimal location, technology and process of DGs investment can be determined from this research. In case A, when load demands are raised in future, feeders and substation transformer will be overloaded. It hence must be necessary to upgrade them to guarantee constraints of capacity limit and voltage profile. However, in case B, DGs will support the capacity of feeders and substation transformer. As a result, the upgrade is not needed. This method offers excellent economic and technical indices. Below comparisons will justify the efficiency of DG in planning of distribution systems.

a) Comparison of economic index

Economic indices between case B and case A are compared in Table XI.

TABLE XI. COMPARISON OF INVESTMENT, O&M AND ELECTRICAL ENERGY COST BETWEEN CASE B AND A

TT	Cost	Total cost (M\$)		Comparison cost between Case B and Case A	Note
		Case A	Case B		
1	Substation Transformer upgrading	1.00	0.00	-1	Total costs is reduced -8.99%
2	Feeder upgrading	1.98	0.00	-1.98	
3	O&M and Electrical energy	47.82	40.74	-7.08	
4	Investment DG	0.00	5.5	5.5	
Total		50.8	46.24	-4.56	

As can be seen from the Table XI, Case B holds a better economic index. Costs of DGs investment and equipment

upgrades (feeders and substation) are more expensive those of case A by 2.52M\$ due to a very high cost of DGs investment. For instance, capital cost of PV should be 5.0M\$/MW. Nevertheless, O&M and electric energy expenses have been decreased by 7.08M\$ because of very low O&M and fuel expenses of DGs. For example, PV has zero cost of fuel. Therefore, the efficiency gets higher as time reaches to final years of planning period. What is more, total costs of case B are cheaper than these of case A by 4.56M\$, equal to 8.99%.

b) Comparison of technical index

Total amount of electric energy bought from CEM in case B is continuously reduced during the planning period as given in Figure 2. In the fifth year, this amount has been dropped most significantly with 8,780.0MWh. This should be important to environmental pollution impact because of reduction of traditional power energies. In this research, the planning time is just only 5 years while life-span of electric devices normally reaches to 20 years so that the efficiency of DGs will be much higher.

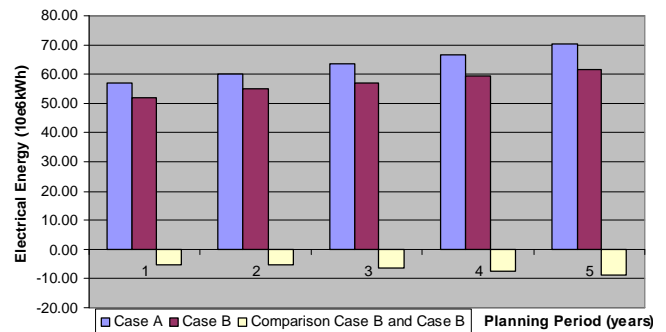

Figure 2. Comparison of electrical energy purchases from electricity markets between Case B and Case A

Active power and electricity energy losses are also one of important indices that can be used to assess the efficiency of the planning project [4]. Figure 3 presents active power losses in two cases and the comparison between them. When DGs investment is selected, active power loss is dropped during all the time of planning. In the first year, this loss has been decreased considerably by 1.11MW and it keeps dropping in following years. 1.95MW is a significant drop in the last year. This leads to a reduction of electric energy costs by 12,940.0MWh corresponding to 1.29M\$.

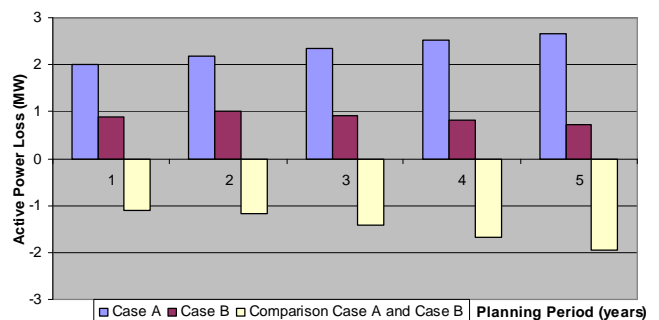

Figure 3. Comparison of active power loss between Case B and Case A

Voltages at load nodes in cases A and B are represented in Figure 4 and 5, respectively. It can be seen that voltage profiles in case A at remote nodes are low at the first year. Voltages of 17th and 18th nodes are less than 0.9pu. In following years, voltages at all nodes are dropped significantly and most of load nodes get voltages that are less than 0.9pu at final year. Voltage of 18th node is smallest at 0.79pu.

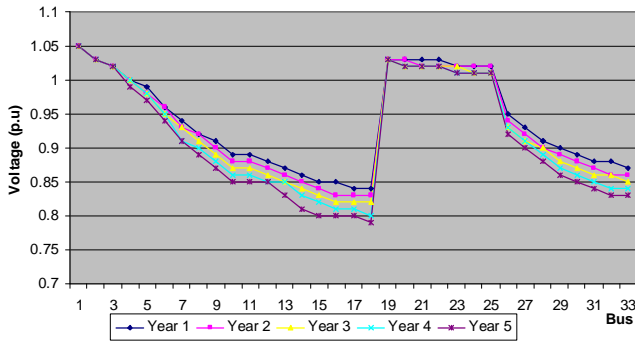

Figure 4. Bus voltage profiles in Case A

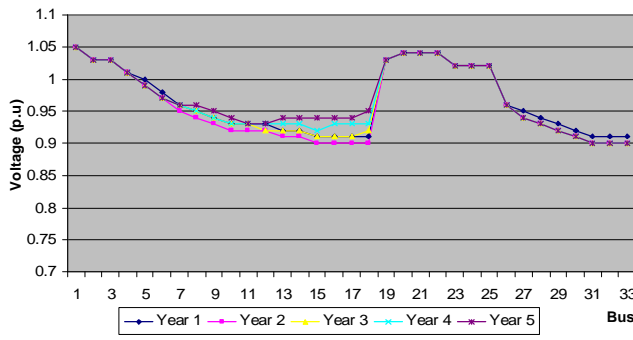

Figure 5. Bus voltage profiles in Case B

Figure 5 shows that voltages at load nodes are enhanced remarkably in case B. During planning time, voltage profiles at all load nodes are greater than 0.9pu. This is because DGs decrease voltage drops. In the fifth year, nodal voltages receive the greatest support.

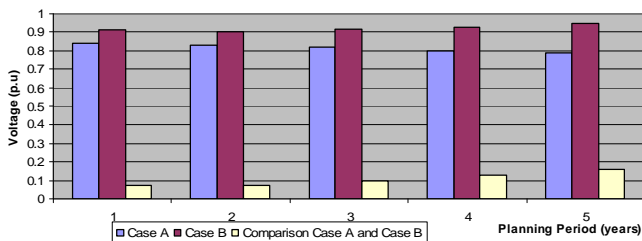

Figure 6. Comparison voltage profile of bus 18 between Case B and Case A

Load node having the biggest support is 18th node in which optimal investing decision of the model selects the highest power by 2.8MW. Figure 6 illustrates voltages profile of the 18th nodal in both cases within planning time. In case B, voltage profile is improved in the first year immediately and is still maintained at excellent values in following years. The voltage improvement of case B compared to case A is raised gradually from the first year to the fifth year and it gets the maximum at 0.16pu.

Voltage comparison between two cases in the final year points out supported voltages at all nodes, when DGs are installed as give in Figure 7.

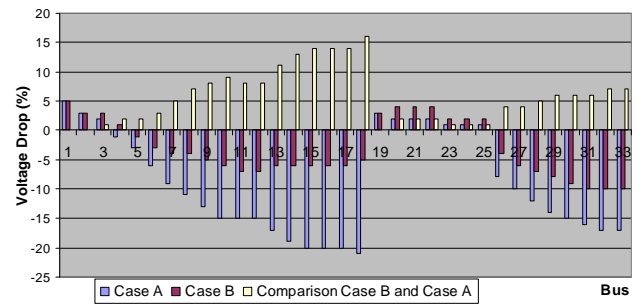

Figure 7. Comparison voltage drops between Case B and Case A

It is assumed that substation transformer node voltage is constant (1.05pu) and the length of feeders is short. Hence, voltage drops at nodes, which are close to substation transformer, are small. In case B, voltage drops of far load nodes have been reduced sharply. At 33rd node, voltage drop goes down moderately from 17% to 10% but this drop has a significant reduction of 16% at 18th node.

IV. CONCLUSION

Planning of distribution systems have been change significantly for recent years because of reconstruction process of CEM, technological development and environmental pollutions, promoted the development of DGs and renewable energy resources, in particular. The new proposed model for planning of distribution systems has allowed selecting DGs as an optimum. The objective function is minimum quantity of total costs of investing and upgrading costs of feeders and substation transformers, building cost of new DGs, operating fees as well as fuel cost of DGs and electricity energy expenses purchase from CEM via connected substation transformers. All these costs are converted to the first year of planning period. Nodal power balance between supplies and load demands, DG power limitation, efficiency of existing equipments, required nodal voltage drop are constraints of this research model so that they can guarantee technical requirements. An optimal process can be estimated (time and power) to upgrade and reconstruct feeders and substation transformers, and choose optimal locations, power and investing process of DGs. Particularly, DG technology can be selected in this model via economic and technical indices. It can be seen from the results that planning together with using DG usually provides better economic and technical outcomes. Total investing and operating costs of planning of distribution system, converted to the base year, have been reduced, active power and electricity energy losses have been decreased, voltage profiles have been supported and upgrading time of existing feeders and substation transformer has been delayed. Furthermore, reduction of electricity energy purchased CEM has limited the use of traditional energy resources, which contributes to the decrease of environmental pollution.

APPENDIX A. DATA OF LOAD FOR 33 BUS RADIAL DISTRIBUTION SYSTEM

No	Bus	PD ₀ (kW)	QD ₀ (kVAr)	No	Bus	PD ₀ (kW)	QD ₀ (kVAr)
1	1	-	-	18	18	490	440
2	2	200	160	19	19	190	140
3	3	290	240	20	20	290	220
4	4	320	250	21	21	190	140
5	5	160	130	22	22	390	340
6	6	360	310	23	23	390	350
7	7	300	300	24	24	420	350
8	8	300	300	25	25	220	200
9	9	160	120	26	26	660	525
10	10	220	160	27	27	560	525
11	11	145	110	28	28	360	310
12	12	160	135	29	29	420	370
13	13	460	435	30	30	300	200
14	14	220	180	31	31	550	470
15	15	560	460	32	32	310	260
16	16	260	200	33	33	460	390
17	17	360	320		Total	10,675	9,040

* Where: PD₀, QD₀ - active and reactive power demand at bus in base year of planning period

APPENDIX B. DATA OF FEEDER PARAMETERS FOR 33 BUS RADIAL DISTRIBUTION SYSTEM

No	Bus i - Bus j	F _{ij} (mm ²)	S _{max,ij} (MVA)	L _{ij} (km)	R _{fij} (W)	X _{fij} (W)
1	1.2	AC-150	16.96	1.5	0.2910	0.5760
2	2.3	AC-150	16.96	0.6	0.1164	0.2304
3	3.4	AC-95	12.57	1.6	0.5024	0.6352
4	4.5	AC-95	12.57	1.5	0.4710	0.5955
5	5.6	AC-95	12.57	2.1	0.6594	0.8337
6	6.7	AC-35	6.67	2.5	1.9325	1.0725
7	7.8	AC-35	6.67	1.1	0.8503	0.4719
8	8.9	AC-25	4.95	1.6	1.8336	0.6880
9	9.10	AC-25	4.95	1.5	1.7190	0.6450
10	10.11	AC-25	4.95	0.2	0.2292	0.0860
11	11.12	AC-25	4.95	0.4	0.4584	0.1720
12	12.13	AC-25	4.95	1.2	1.3752	0.5160
13	13.14	AC-25	4.95	1.4	1.6044	0.6020
14	14.15	AC-25	4.95	1.3	1.4898	0.5590
15	15.16	AC-25	4.95	1.6	1.8336	0.6880
16	16.17	AC-25	4.95	1.2	1.3752	0.5160
17	17.18	AC-25	4.95	0.8	0.9168	0.3440
18	2.19	AC-25	4.95	0.2	0.2292	0.0860
19	19.20	AC-25	4.95	1.3	1.4898	0.5590
20	20.21	AC-25	4.95	0.3	0.3438	0.1290
21	21.22	AC-25	4.95	0.7	0.8022	0.3010
22	3.23	AC-25	4.95	1.4	1.6044	0.6020
23	23.24	AC-25	4.95	0.8	0.9168	0.3440
24	24.25	AC-25	4.95	0.8	0.9168	0.3440
25	6.26	AC-35	6.67	1.5	1.1595	0.6435
26	26.27	AC-35	6.67	2.2	1.7006	0.9438

27	27.28	AC-25	4.95	1.7	1.9482	0.7310
28	28.29	AC-25	4.95	1.8	2.0628	0.7740
29	29.30	AC-25	4.95	1.3	1.4898	0.5590
30	30.31	AC-25	4.95	2	2.2920	0.8600
31	31.32	AC-25	4.95	2.2	2.5212	0.9460
32	32.33	AC-25	4.95	1.4	1.6044	0.6020

* Where: S_{max} - Maximum capacity limit for Feeder

REFERENCES

- [1] P. Frase and S. Morita, "Distributed Generation in liberalised electricity markets", International Energy Agency, IEA Publications 2002. p.20.
- [2] Thomas Ackermann, Go'ran Andersson, Lennart So'der, "Distributed generation: a definition", Electric Power Systems Research 57, 2001.
- [3] S. Wong, K. Bhattacharya and J.D.Fuller, "Comprehensive framework for long-term distribution system planning", Proc. IEEE PES Annual General Meeting, Tampa, USA, 2007.
- [4] N. Mithulananthan, Than Oo and Le Van Phu, "Distributed Generator Placemintn Power Distribution System Using Genetic Algorithm to Reduce Losses", Thammasat International Journal of Science and Technology, 2004.
- [5] Amin Hajizadeh, Ehsan Hajizadeh, "PSO-Based Planning of Distribution Systems with Distributed Generations", International Journal of Electrical, Computer, and Systems Engineering 2008.
- [6] Vinoth Kumar, K. and Selvan, M.P., "Planning and Operation of Distributed Generations in Distribution Systems for Improved Voltage Profile", IEEE PES Power Systems Conference and Exposition (PSCE 2009), March 15-18, 2009, Washington, USA
- [7] A.Soroudi and M.Ehsan, "Multi Objective Distributed Generation Planning in Liberalized Electricity Markets", Transmission and Distribution Conference and Exposition, 2008. IEEE/PES
- [8] Muhammad Ahmadi, Ashkan Yousefi, Alireza Soroudi, Mehdi Ehsan, "Multi Objective Distributed Generation Planning Using NSGA-II", 13th International Power Electronics and Motion Control Conference (EPE-PEMC 2008).
- [9] Algarni, A.A.S.; Bhattacharya, K., "A Novel Approach to Disco Planning in Electricity Markets: Mathematical Model", Power Systems Conference and Exposition, 2009. PSCE '09. IEEE/PES
- [10] El-Khattam, W.; Hegazy, Y.; Salama, M., "An integrated distributed generation optimization model for distribution system planning", Power Engineering Society General Meeting, 2005. IEEE
- [11] S. Wong, K. Bhattacharya and J.D. Fuller, "Electric power distribution system design and planning in a deregulated environment", IET Generation, Transmission & Distribution, 2009.
- [12] El-Khattam, W.; Bhattacharya, K.; Hegazy, Y.; Salama, M.M.A., "Optimal investment planning for distributed generation in a competitive electricity market", Power Systems, IEEE Transactions on Volume: 19, 2004.
- [13] GAMS 20.5, A User's Guide, GAMS Development Corporation, 1998.